

Communication Interface Module Replacement

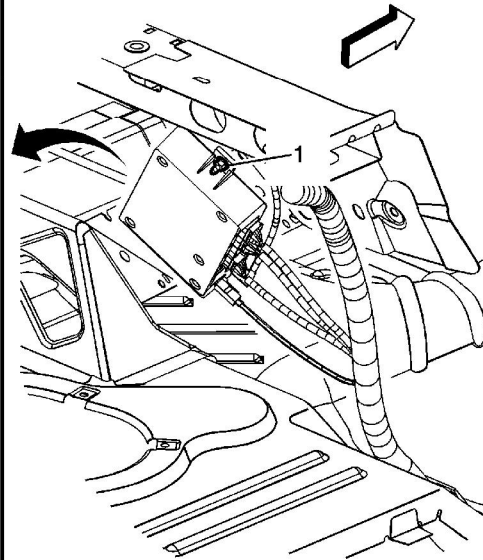
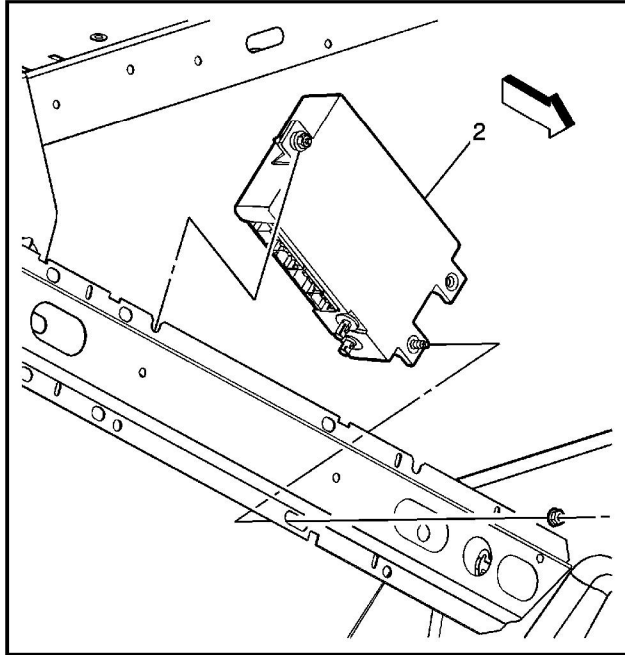

Callout	Component Name
<p>Notice: Refer to Fastener Notice in the Preface section.</p>	
<p>Important: The vehicle communication interface module (VCIM) has a specific set of unique numbers that tie the module to each vehicle. These numbers, the 10-digit station identification and the 11-digit electronic serial number, are used by the National Cellular Network and OnStar® to identify the specific vehicle. Because these numbers are tied to the vehicle identification number of the vehicle, you must never exchange these parts with those of another vehicle.</p>	
<p>Important: After replacing the vehicle communication interface module, you must reconfigure the OnStar® system. Failure to reconfigure the system will result in an additional customer visit for repair. In addition, pressing and holding the white dot button on the keypad will NOT reset this version of the OnStar® system. This action will cause a DTC to set.</p>	
<p><i>Fastener Tightening Specifications:</i> Refer to Fastener Tightening Specifications .</p>	
<p>Preliminary Procedure</p>	
<p>1. Remove the front rear compartment trim. Refer to Rear Compartment Front Trim Panel Replacement .</p>	

© 2012 General Motors Corporation. All rights reserved.

2. Program the communication interface module (OnStar®) after replacement. Refer to [Control Module References](#) .

1	Navigation Receiver Nut (Qty: 2) Tighten 3.5 N·m (31 lb in)
2	Navigation Receiver Assembly